

- Page 1
Section
Dimensions
Car data
- Page 2
Width
Dimensions
- Page 3
Approach
Load plan
Installation
- Page 4
Electrical
Installation
Technical
data
- Page 5
To be performed
by the customer
Description

Type G32-155

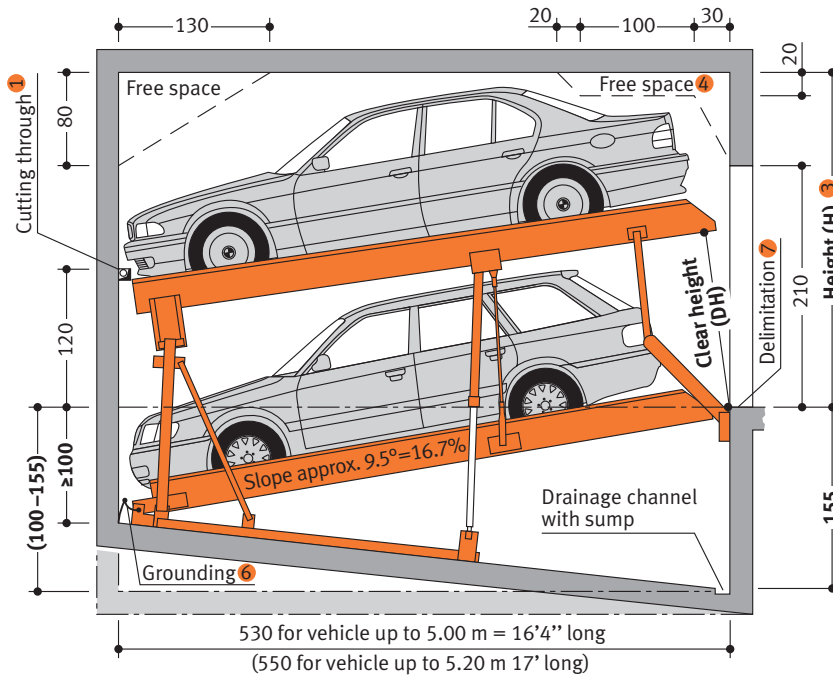

Typ G22-135

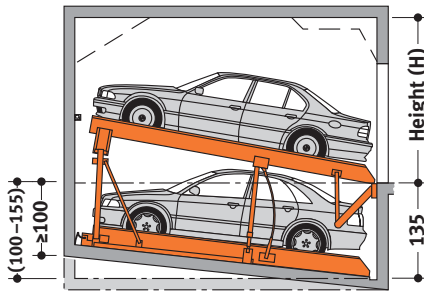

Typ G32-160

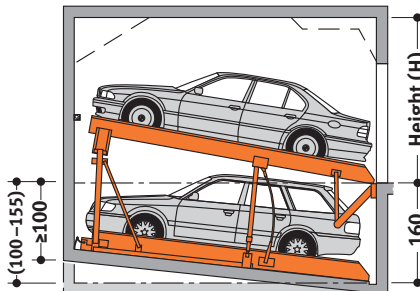

Garage with door in front of the car parking system

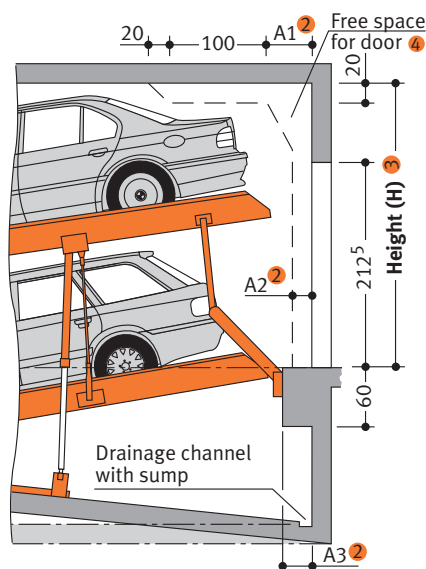

Notes

- 1 For dividing walls: cutting through 10 x 10 cm (for pipes).
- 2 Dimensions A1, A2 and A3 must be coordinated with the door supplier.
- 3 If the total height is greater, the max. vehicle height for the upper parking space increases accordingly.
- 4 Clearance zone does not apply for station wagons/estate cars on the upper parking places.
- 5 On the upper and lower parking spaces passenger cars with roof racks or station wagon/estate car without roof racks. Height of car with roof rack 1.60 m.
- 6 Potential equalization from foundation grounding connection to system (provided by the customer).
- 7 In compliance with DIN EN 14 010, 10 cm wide yellow-black markings compliant to ISO 3864 must be applied by the customer to the edge of the pit in the entry area to mark the danger zone (see »load plan« page 3).

Product Data
Double Parker
G22/G32

Dimensions:
 All space requirements are minimum finished dimensions. Tolerances for space requirements $+3_0$. Dimensions in cm.
 EB (single platform) = 2 vehicles
 DB (double platform) = 4 vehicles

Type	H	DH**
G22-135	295	154
G32-155	295	154
G32-155	310	154
G32-160*	325	170

* = standard type ** = without car
Suitable for:
 Standard passenger car and station wagon.
 Height and length according to contour.

Type	H	upper	lower
G22-135	295	only cars height 1.50m	only cars height 1.50m
G32-155	295	only cars height 1.50m	car/sw** height 1.50m
G32-155	310	car/sw height 1.50m	car/sw height 1.50m
G32-160*	325	car/sw height 1.60m	car/sw height 1.60m

* = standard type ** sw = station wagon
 Note: There are restrictions for parking various cars or cars with roof antennas, low profile tires, front/rear spoilers on the upper and lower parking places since their vehicle contours lie outside of the permissible dimensions we allow. Individual adjustments for the respective cars are only partly possible at an additional charge. We are not liable in any way in the event of noncompliance and any resulting damage or consequential follow-up costs. To avoid problems of this nature we recommend planning and building our types 2042, G82, G62, 2062 or 2082.

width	1.90 m
weight	max. 2000 kg
wheel load	max. 500 kg

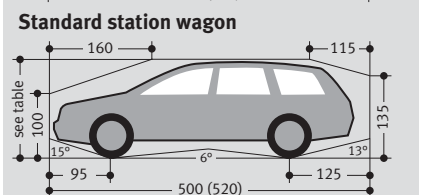
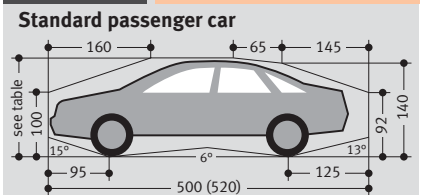

Standard passenger cars are vehicles without any sports options such as spoilers, low-profile tyres etc.

KLAUS
 multiparking

Klaus Multiparking GmbH
 Hermann-Krum-Straße 2
 D-88319 Aitrach

Phone +49-75 65-5 08-0
 Fax +49-75 65-5 08-88
 E-Mail info@multiparking.com
 Internet www.multiparking.com

- Page 1
Section
Dimensions
Car data
- Page 2
Width
dimensions
- Page 3
Approach
Load plan
Installation
- Page 4
Electrical
installation
Technical
data
- Page 5
To be performed
by the customer
Description

Width for basement garage

Dividing walls

Single Platform (EB)

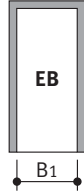

usable platform width	B1
230 *	260
240	270
250	280
260	290
270	300

Double Platform (DB)

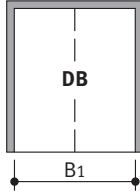

usable platform width	B1
460 *	490
470	500
480	510
490	520
500	530

Single and Double Platform (EB + DB) – Example

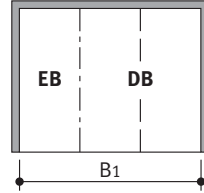

usable platform width	B1
230 + 460 *	750
240 + 470	770
250 + 480	790
250 + 500	810
270 + 500	830

Carriageway in accordance with local regulations

Columns in pit

Single Platform (EB)

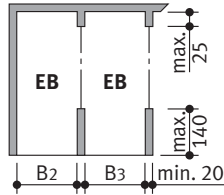

usable platform width	B2	B3
230 *	255	250
240	265	260
250	275	270
260	285	280
270	295	290

Double Platform (DB)

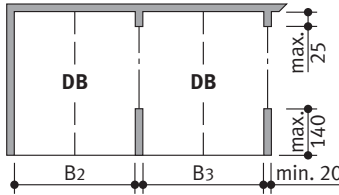

usable platform width	B2	B3
460 *	485	475
470	495	485
480	505	495
490	515	505
500	525	515

Single and Double Platform (EB + DB) – Example

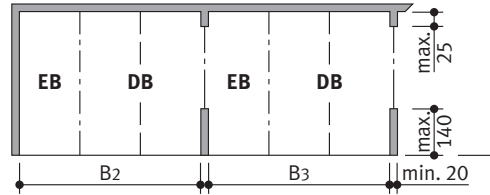

usable platform width	B2	B3
230 + 460 *	745	735
240 + 470	765	755
250 + 480	785	775
250 + 500	805	795
270 + 500	825	815

Carriageway in accordance with local regulations

Columns outside pit

Single Platform (EB)

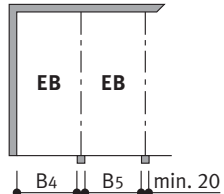

usable platform width	B4	B5
230 *	250	240
240	260	250
250	270	260
260	280	270
270	290	280

Double Platform (DB)

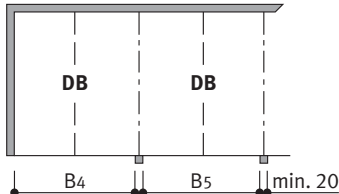

usable platform width	B4	B5
460 *	480	470
470	490	480
480	500	490
490	510	500
500	520	510

Single and Double Platform (EB + DB)

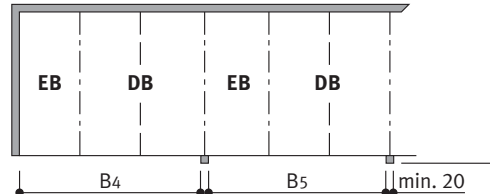

usable platform width	B4	B5
230 + 460 *	740	730
240 + 470	760	750
250 + 480	780	770
250 + 500	800	790
270 + 500	820	810

Carriageway in accordance with local regulations

Widths for garage with door in front of car parking system

Single platform (EB)

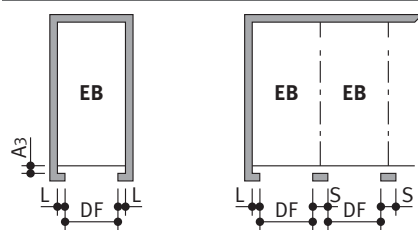

A3 = seat-engaging surface (dimensions require coordination with door supplier.)

Allround door dimensions require coordination between door supplier and local agency of Klaus Multiparking.

usable platform width	door entrance width DF	L	S
230 *	237 ^s	12 ^s	25
240	250	12 ^s	25
250	250	15	30
260	260	15	30
270	270	15	30

Double platform (DB)

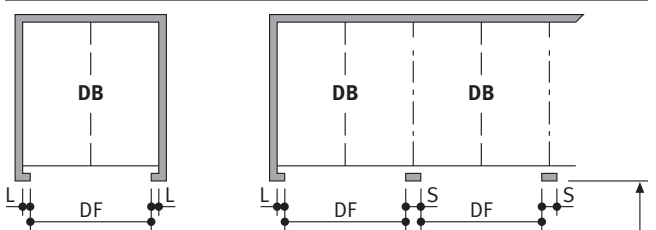

Carriageway in accordance with local regulations

usable platform width	door entrance width DF	L	S
460 *	460	15	30
475	475	12 ^s	25
480	475	17 ^s	35
490	500	12 ^s	25
500	500	15	30

* = standard width (parking space width 2.30 m)

ⓘ = no standard width for doors!

Please note:



End parking spaces are generally more difficult to drive into. Therefore we recommended for end parking spaces our wider platforms. Parking on standard width platforms with larger vehicles may make getting into and out of the vehicle difficult. This depends on type of vehicle, approach and above all on the individual driver's skill.

- Page 1
Section
Dimensions
Car data
- Page 2
Width
Dimensions
- Page 3
Approach
Load plan
Installation
- Page 4
Electrical
Installation
Technical
Data
- Page 5
To be performed
by the
customer
Description

Approach

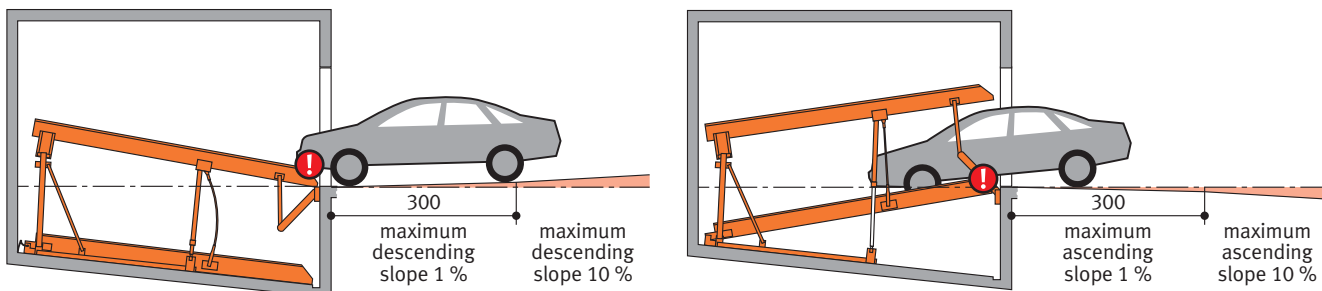

! The illustrated maximum approach angles must not be exceeded. Incorrect approach angles will cause serious manoeuvring & positioning problems on the parking system for which the local agency of Klaus accepts no responsibility.

Load plan

Forces in kN

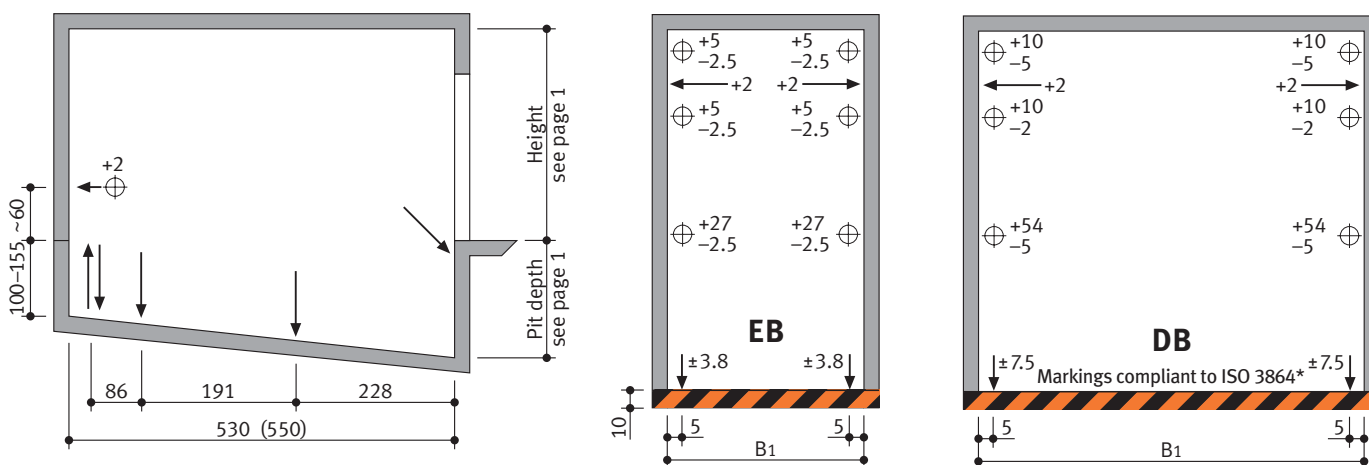

! Units are dowelled to the floor. Drilling depth: approx. 15 cm. Floor and walls below the drive-in level are to be made of concrete (quality minimum C20/25)!

* = Colors used in this illustration are not ISO 3864 compliant

Installation data

Free space for longitudinal and vertical ducts (e.g. ventilation)

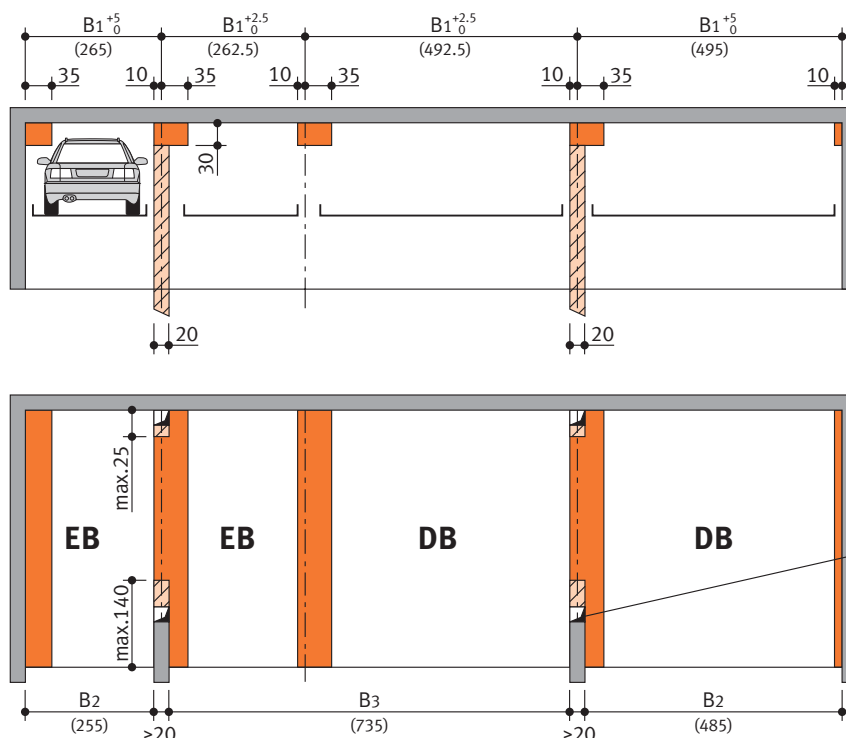

B₁, B₂, B₃ = (see table on page 2)

Free space for vertical pipelines, ventilation branch canals

Free space for horizontal ducting

Approach level

Free space only applicable if vehicle is parked forwards = FRONT FIRST and driver's door on the left side.

() = Dimensions in brackets illustrate an example for usable platform width 230/460 cm.

Example for ventilation branch canal and/or vertical pipelines.

- Page 1
Section
Dimensions
Car data
- Page 2
Width
Dimensions
- Page 3
Approach
Load plan
Installation
- Page 4
Electrical
Installation
Technical
data
- Page 5
To be performed by the customer
Description

Electrical installation

Installation diagram

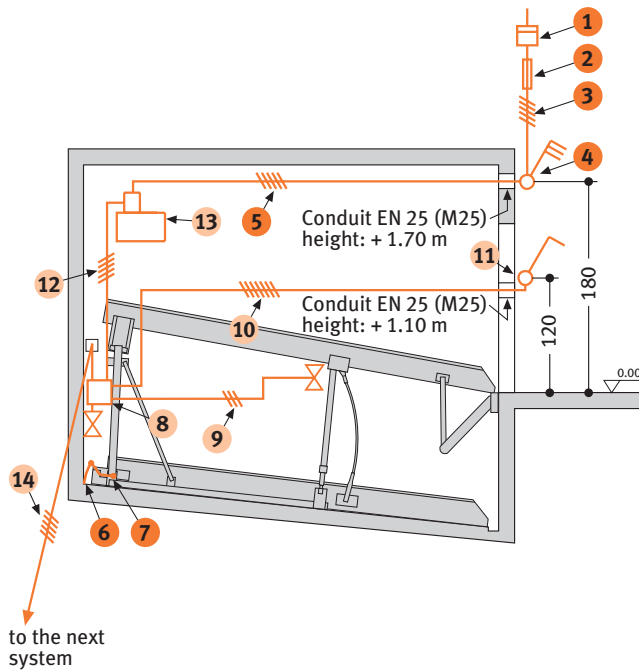

Electrical data (to be performed by the customer)

No.	Quantity	Description	Position	Frequency
1	1	Electricity meter	in the supply line	
2	1	Main fuse: 3 x fuse 10 A (slow) or circuit breaker 3 x 10 A (trigger characteristic K or C)	in the supply line	1 per unit
3	1	Supply line 5 x 1.5 mm ² (3 PH + N + PE) with marked wire and protective conductor	to main switch	1 per unit
4	1	Lockable main switch	defined at the plan evaluation	1 per unit
5	1	Supply line 5 x 1.5 mm ² (3 PH + N + PE) with marked wire and protective conductor	from main switch to unit	1 per unit
6	every 10 m	Foundation earth connector	corner pit floor	
7	1	Equipotential bonding in accordance with DIN EN 60204 from foundation earth connector to the system		1 per system

Electrical data (included in delivery of Klaus Multiparking)

No.	Description
8	Terminal box
9	Control line 3 x 0.75 mm ² (PH + N + PE)
10	Control line 7 x 1.5 mm ² with marked wire and protective conductor
11	Operating device
12	Control line 5 x 1.5 mm ² with marked wire and protective conductor
13	Hydraulic unit 1.5 kW, three-phase current, 400 V / 50 Hz
14	Control line 5 x 1.5 mm ² with marked wire and protective conductor

Technical data

Range of application

Generally, this parking system is not suited for short-time parkers (temporary parkers). Please do not hesitate to contact your local KLAUS agency for further assistance.

Units

Low-noise power units mounted to rubber-bonded-to metal mountings are installed. Nevertheless we recommend that parking system's garage be built separately from the dwelling.

Available documents

- wall recess plans
- maintenance offer/contract
- declaration of conformity
- test sheet on airborne and slid-borne sound

Corrosion protection

See separate sheet regarding corrosion protection.

Railings

If the permissible drop opening is exceeded, railings are to be mounted on the systems. If there are traffic routes next to or behind the installations, railings compliant to DIN EN ISO 13857 must be installed by the customer. Railings must also be in place during construction.

Environmental conditions

Environmental conditions for the area of multiparking systems: Temperature range -10 to +40° C. Relative humidity 50 % at a maximum outside temperature of +40° C.

If lifting or lowering times are specified, they refer to an environmental temperature of +10° C and with the system set up directly next to the hydraulic unit. At lower temperatures or with longer hydraulic lines, these times increase.

Sound insulation

According to DIN 4109 (Sound insulation in buildings), para. 4, annotation 4, Klaus Multiparkers are part of the building services (garage systems).

Normal sound insulation:

DIN 4109, para. 4, Sound insulation against noises from building services.

Table 4 in para. 4.1 contains the permissible sound level values emitted from building services for personal living and working areas. According to line 2 the maximum sound level in personal living and working areas must not exceed 30 dB (A).

Noises created by users are not subject to the requirements (see table 4, DIN 4109).

The following measures are to be taken to comply with this value:

- Sound protection package according to offer/order (Klaus Multiparking GmbH)
- Minimum sound insulation of building $R'_w = 57$ dB (to be provided by customer)

Increased sound insulation (special agreement):

DIN 4109, Amendment 2, Information on planning and execution, proposals for increased sound insulation.

Agreement: Maximum sound level in personal living and working areas 25 dB (A). *Noises created by users are not subject to the requirements (see table 4, DIN 4109).*

The following measures are to be taken to comply with this value:

- Sound protection package according to offer/order (Klaus Multiparking GmbH)
- Minimum sound insulation of building $R'_w = 62$ dB (to be provided by customer)

Note: User noises are noises created by individual users in our Multiparking systems. These can be noises from accessing the platforms, slamming of vehicle doors, motor and brake noises.

Page 1
Section
Dimensions
Car data

Page 2
Width
Dimensions

Page 3
Approach
Load plan
Installation

Page 4
Electrical
Installation
Technical
data

Page 5
To be performed
by the customer
Description

To be performed by the customer

Safety fences

Any constraints that may be necessary according to DIN EN ISO 13857 in order to provide protection for the park pits for pathways directly in front, next to or behind the unit. This is also valid during construction. Railings for the system are included in the series delivery when necessary.

Numbering of parking spaces

Consecutive numbering of parking spaces.

Building services

Lighting, ventilation, fire extinguishing and fire alarm systems.

Drainage

For the front area of the pit we recommend a drainage channel, which you connect to a floor drain system or sump (50 x 50 x 20 cm). The drainage channel may be inclined to the side, however not the pit floor itself (longitudinal incline is available). For reasons of environmental protection we recommend to paint the pit floor, and to provide oil and petrol separators in the connections to the public sewage network.

Strip footings

If due to structural conditions strip footings must be effected, the customer shall provide an accessible platform reaching to the top of the said strip footings to enable and facilitate the mounting work.

Marking

According to DIN EN 14 010, a warning that identifies this danger area must be placed in the entrance area that conforms to ISO 3864. This must be done according to EN 92/58/EWG for systems with a pit (platforms within the pit) 10 cm from the edge of the pit.

Wall cuttings

Any necessary wall cuttings according to page 1.

Electrical supply to the main switch / Foundation earth connector

Suitable electrical supply to the main switch and the control wire line must be provided by the customer during installation. The functionality can be monitored on site by our fitters together with the electrician. If this cannot be done during installation for some reason for which the customer is responsible, the customer must commission an electrician at their own expense and risk.

In accordance with DIN EN 60204 (Safety of Machinery. Electrical Equipment), grounding of the steel structure is necessary, provided by the customer (distance between grounding max. 10 m).

Operating device

Cable conduits and recesses for operating device (for double wing doors: please contact the local agency of Klaus Multiparking).

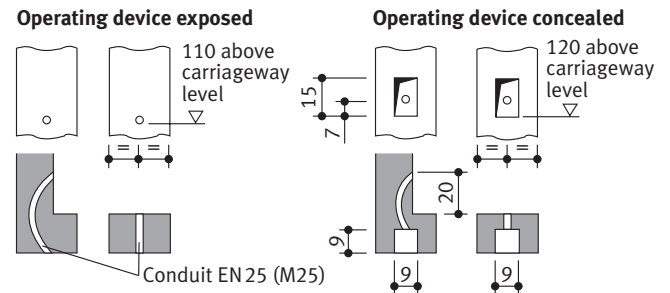

If the following are not included in the quotation, they will also have to be provided / paid for by the customer:

- Mounting of contactor and terminal box to the wall valve, complete wiring of all elements in accordance with the circuit diagram
- Costs for final technical approval by an authorized body
- Main switch
- Control line from main switch to hydraulic unit

Description Single platform (EB) and Double platform (DB)

General description

Multiparking system providing independent parking spaces for 2 cars (EB), 2 x 2 cars (DB), one on top of the other each.

Dimensions are in accordance with the underlying dimensions of parking pit, height and width

The parking bays are accessed inclined (by approx. 9.5 degrees).

Vehicles are positioned on each parking space using wheel stops on the right side (adjust according to operating instructions).

Operation via operating device with hold-to-run-device using master keys.

The operating elements are usually mounted either in front of the column or on the outside of the door frame

Operating instructions are attached to each operator's stand.

For garages with doors at the front of the parking system the special dimensional requirements have to be taken into account.

Multiparking system consisting of:

- 2 base elements (mounted on the floor)
- 2 pillars (mounted on the base elements)
- 2 platforms
- 1 torsion bar (to ensure synchronous operation of the hydraulic cylinders while lowering and lifting the platform)
- 2 hydraulic cylinders
- 2 hoisting ropes (connect the platforms)
- 1 automatic hydraulic safety valve (prevents accidental lowering of the platform while accessing the platform)
- Dowels, screws, connecting elements, bolts, etc.
- The platforms and parking spaces are end-to-end accessible for parking!

Platforms consisting of:

- Platform base sections
- Adjustable wheel stops
- Canted access plates
- Side members
- Central side member [only DB]
- Cross members [DB long and short cross members]
- Safety railings - along the upper and lower platform (if required)
- Screws, nuts, washers, distance tubes, etc.

Hydraulic system consisting of:

- Hydraulic cylinder
- Solenoid valve
- Safety valve
- Hydraulic conduits
- Screwed joints
- High-pressure hoses
- Installation material

Electric system consisting of:

- Operating device (Emergency Stop, lock, 1 master key per parking space)
- Terminal box at wall valve

Hydraulic unit consisting of:

- Hydraulic power unit (low-noise, installed onto a console with a rubber-bonded-to-metal mounting)
- Hydraulic oil reservoir
- Oil filling
- Internal geared wheel pump
- Pump holder
- Clutch
- 3-phase-AC-motor (1.5 kW, 230/400 V, 50 Hz)
- Contactor (with thermal overcurrent relay and control fuse)
- Test manometer
- Pressure relief valve
- Hydraulic hoses (which reduce noise transmission onto the hydraulic pipe)

We reserve the right to change this specification without further notice

The Klaus company reserves the right in the course of technical progress to use newer or other technologies, systems, processes, procedures or standards in the fulfillment of their obligations other than those originally offered provided the customer derives no disadvantage from their so doing.